



**PRODUCT, DESIGN AND INSTALLATION GUIDELINES**  
**PLASTIC CHAINS**



|  |           |
|--|-----------|
| <b>Section 1: Introduction</b> .....                         | <b>4</b>  |
| About Intralox.....  | 4         |
| About This Manual.....                                       | 4         |
| <b>Section 2: Material Guidelines</b> .....                  | <b>5</b>  |
| Chain Model Selection Guidelines .....                       | 5         |
| Chains.....  | 5         |
| Pins.....  | 5         |
| Sprockets .....  | 6         |
| Friction .....   | 6         |
| <b>Section 3: Product Line</b> .....                         | <b>7</b>  |
| <b>Section 4: Design Guidelines</b> .....                    | <b>25</b> |
| Basic Design Elements.....                                   | 25        |
| Sprockets and Shafts.....                                    | 25        |
| Carryway Design .....  | 26        |
| Returnway Design .....                                       | 27        |
| Wearstrip Materials.....                                     | 27        |
| Thermal Expansion and Contraction .....                      | 28        |
| Catenary Sag.....  | 28        |
| General Returnway Layout .....                               | 29        |
| <b>Section 5: Installation Guidelines</b> .....              | <b>30</b> |
| Installation/Removal of Pins on Straight Running Chains..... | 30        |
| Installation/Removal of Pins on Sideflexing Chains .....     | 30        |
| <b>Section 6: Maintenance/Troubleshooting</b> .....          | <b>31</b> |
| Replacement Guide .....                                      | 31        |



## About Intralox

Intralox, the global leader for conveyance solutions and services, has extended its industry-leading customer support and guarantees to a new product offering: plastic chains. Now, equipment manufacturers and end users can turn to a single source to purchase modular plastic belting, Activated Roller Belt™ (ARB™) technology, ThermoDrive® technology, spiral solutions, and plastic chains.

Ordering through Intralox ensures not only the convenience of partnering with just one vendor, but also the industry expertise, award-winning customer service and support, and unmatched guarantees that Intralox customers know well.

## About This Manual

The information contained in this manual will cover the basic performance data, conveyor design, and installation guidelines for the plastic chain products sold by Intralox.

These are general recommendations, and should work for most application circumstances.

## CHAIN MODEL SELECTION GUIDELINES

- **Straight running vs. Sideflexing:** Series 820, 821, and 831 are straight running chains. Series 878, 879, 880, 882, and 1060 which are sideflexing modules, have the ability to negotiate corners.
- **Chain width:** Width should be determined by the product being conveyed. For example, single file beverage containers may use 3.25 in (83 mm) chains.
- **Materials:** LF Acetal is suitable for most purposes. Ultra Performance is most suitable for higher-speed applications, as it offers lower friction and longer wear life.
- **Wing thickness:** Should be selected to match the height of the conveyors surrounding the target conveyor.

| Wing Thickness |       |     |
|----------------|-------|-----|
| Series         | in    | mm  |
| 820            | 0.157 | 4.0 |
| 821            | 0.189 | 4.8 |
| 831            | 0.189 | 4.8 |
| 878            | 0.189 | 4.8 |
| 879            | 0.189 | 4.8 |
| 880            | 0.157 | 4.0 |
| 882            | 0.189 | 4.8 |
| 1060           | 0.343 | 8.7 |

## CHAINS

**LF Acetal** thermoplastic chains meet both mechanical and thermal needs.

- Demonstrates fatigue endurance and resilience, as well as resistance to impact and abrasion.
- Suitable for container handling and transport due to its low coefficient of friction.
- Temperature range: -40°F (-40°C) to 176°F (80°C).
- Specific gravity: 1.40.
- Relatively impact resistant, cut and scratch resistant.

**Ultra Performance** thermoplastic chains have been modified for lower friction and better wear resistance.

- Based on PBT thermoplastic, a polyester.
- Lower friction against most carryway materials when compared to LF Acetal.
- Suitable for higher speeds than LF Acetal, especially in turning chain applications.
- Temperature range is -40°F (-40°C) to 248°F (120°C).
- Specific gravity is 1.31.

## PINS

- Series 820, 821, 831, 878, 879, 880, and 882 chains use an austenitic stainless steel pin
- Series 880 and 1060 M chains use a ferritic stainless steel pin that is attracted to a magnetic track.

## SPROCKETS

### Glass-Filled Nylon

- Available for Series 820, 878, 879, 880, and 1060.
- Offers increased abrasion, chemical, and fatigue resistance.
- Temperature range: -51°F (-46°C) to 151°F (66°C); performs well in low temperatures.
- Abrasion resistant in dry applications.
- Specific gravity: 1.38.

### Nylon

- Available for Series 821, 831 and 882.
- Offers suitable abrasion, chemical, and fatigue resistance.
- Abrasion resistant in dry applications.
- Temperature range: -51°F (-46°C) to 180°F (82°C); performs well in low temperatures.
- Specific gravity: 1.13.

## FRICTION

| Friction Factors  | $F_w$ | Friction between wearstrip and chain<br>Wearstrip material |  |   |  |
|-------------------|-------|--|--|---|--|
| Chain Material    |       | STEEL<br>Dry (Water)<br>[Soap and Water]                   | UHMW PE<br>Dry (Water)<br>[Soap and Water] | RETURN ROLLERS<br>Dry (Water)<br>[Soap and Water] | NYLON<br>Dry (Water)<br>[Soap and Water] |
| LF Acetal         |       | 0.30 (0.23) [0.15]   | 0.25 (0.21) [0.15]                         | 0.10 (0.10) [0.10]                                | 0.20 (0.18) [0.15]                       |
| Ultra Performance |       | 0.22 (0.20) [0.15]   | 0.18 (0.16) [0.15]                         | 0.10 (0.10) [0.10]                                | 0.17 (0.16) [0.14]                       |

| Friction Factors  | $F_p$ | Friction between product and chain<br>Product material (used in backup conditions) |   |  |   |  |
|-------------------|-------|--|---|--|---|--|
| Chain Material    |       | STEEL<br>Dry (Water)<br>[Soap and Water]   | ALUMINUM<br>Dry (Water)<br>[Soap and Water] | PET<br>Dry (Water)<br>[Soap and Water] | GLASS,<br>RETURNABLE<br>Dry (Water)<br>[Soap and Water] | GLASS,<br>ONE WAY<br>Dry (Water)<br>[Soap and Water] |
| LF Acetal         |       | 0.28   | 0.25 (0.20) [0.15]                          | 0.22 (0.16) [0.13]                     | 0.21 (0.14) [0.10]                                      | 0.20 (0.16) [0.13]                                   |
| Ultra Performance |       | 0.20   | 0.18 (0.16) [0.13]                          | 0.15 (0.14) [0.12]                     | 0.13 (0.12) [0.10]                                      | 0.14 (0.13) [0.11]                                   |

## Series 820 Straight Running Chain

|              | in.          | mm    |
|--------------|--------------|-------|
| Pitch, P     | 1.50         | 38.1  |
| Width, W     | 3.25         | 82.5  |
|              | 4.50         | 114.3 |
|              | 7.50         | 190.5 |
| Open Area    | 0%           |       |
| Hinge Style  | Closed       |       |
| Drive Method | Hinge-driven |       |

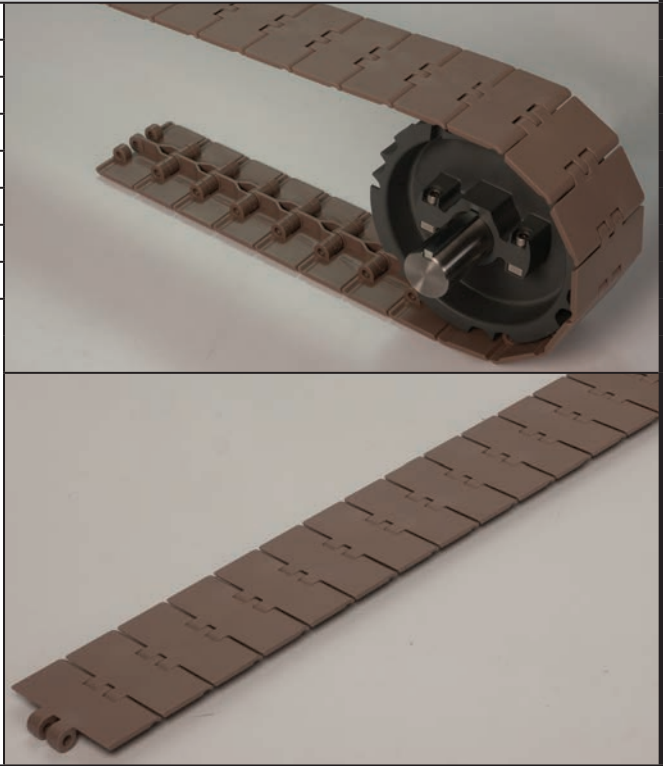
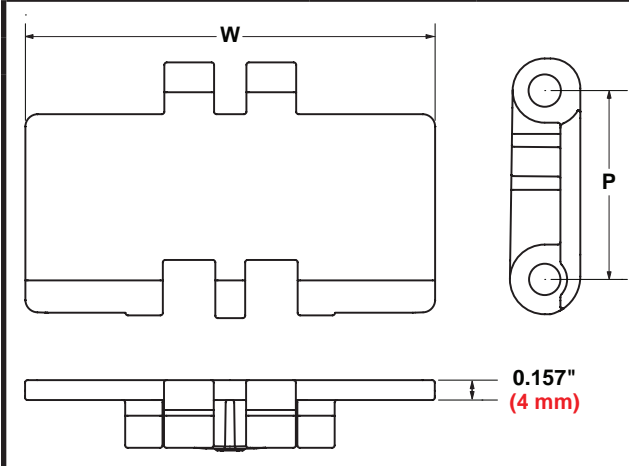

## Series 820 Straight Running Chain Data

| Chain Widths |       | Material  | Color | CS Chain Strength* |     | Temperature Range (continuous) |           | W Chain Weight |      |
|--------------|-------|-----------|-------|--------------------|-----|--------------------------------|-----------|----------------|------|
| in.          | mm    |           |       | lb                 | kg  | °F                             | °C        | lb/ft          | kg/m |
| 3.25         | 82.5  | LF Acetal | Brown | 365                | 166 | -40 to 176                     | -40 to 80 | 0.55           | 0.81 |
| 4.50         | 114.3 | LF Acetal | Brown | 365                | 166 | -40 to 176                     | -40 to 80 | 0.69           | 1.02 |
| 7.50         | 190.5 | LF Acetal | Brown | 365                | 166 | -40 to 176                     | -40 to 80 | 0.95           | 1.41 |

\*Working load.

## Series 820 Sprocket Data

| Number of Teeth | Nom. Pitch Diameter |     | Nom. Outer Diameter |     | Nom. Hub Width |    | Available Bore Sizes |       |              |       |
|-----------------|---------------------|-----|---------------------|-----|----------------|----|----------------------|-------|--------------|-------|
|                 |                     |     |                     |     |                |    | U.S. Sizes           |       | Metric Sizes |       |
|                 | in.                 | mm  | in.                 | mm  | in.            | mm | Round                | Round | Round        | Round |
| 25              | 6.0                 | 152 | 6.1                 | 154 | 2.3            | 59 | 1.25                 | 30    | 35           | 40    |



Drive Sprocket



Idler Sprocket

- **Drive sprockets vs. Idler sprockets:** generally, it is preferred to have a rotating idle shaft, so keyed "drive" sprockets would also be used to rotate the idle shaft in its bearings. If using a fixed idle shaft, use the "idler" sprockets, which have a looser bore and no keyway. A fixed idle shaft is suitable for speeds less than 100 fpm (30 mpm).
- If more than one chain is using the same idle shaft, only the sprocket for one chain should be locked in position. Generally use a keyed drive sprocket on the center most chain, to allow it to turn the shaft. The remaining sprockets will be the idler sprockets, locked using shaft collars to prevent side to side movement.

## Conveyor Frame Dimensions

Regardless of type or configuration, all conveyors using Intralox Chains have some basic dimensional requirements. Specifically, dimensions "A", "B", "C" and "E" listed below should be implemented in any design.

For general applications and applications where end transfer of tip-sensitive product is not critical, use the "A" dimension at the bottom of the range.

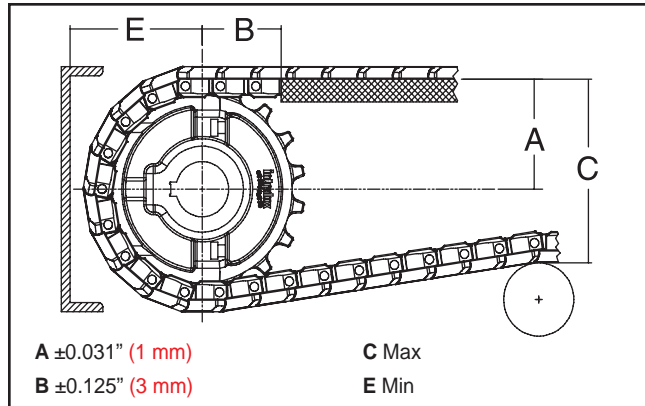

### SERIES 820

| Sprocket Description |     | A                     |           | B     |      | C   |      | E   |      |    |
|----------------------|-----|-----------------------|-----------|-------|------|-----|------|-----|------|----|
| Pitch Diameter       |     | Range (Bottom to Top) |           | in.   | mm   | in. | mm   | in. | mm   |    |
| in.                  | mm  | No. Teeth             | in.       |       |      |     |      |     |      | mm |
| 6.0                  | 152 | 25                    | 3.02-3.12 | 77-79 | 1.50 | 38  | 6.39 | 162 | 3.34 | 85 |

## Dead Plate Gap

Where there is a transfer point from a chain without finger transfer plates to a dead plate, there should be a gap between the surfaces to allow for the chordal action of the chain. As the chain engages its sprockets, chordal action causes the modules to move past a fixed point (the tip of the dead plate) with varying clearances. The table below shows the minimum amount of gap which occurs at the "low point" of the modules if the tip of the dead plate just comes in contact with the "high point" as the modules pass.

In some installations it may be desirable to keep the tip of the dead plate in contact with the chain, rather than allow a gap to occur. This can be done by hinging the mounting bracket for the dead plate. This allows the dead plate to move as the modules pass, but results in a small oscillating motion which may present tippage problems for sensitive containers or products.

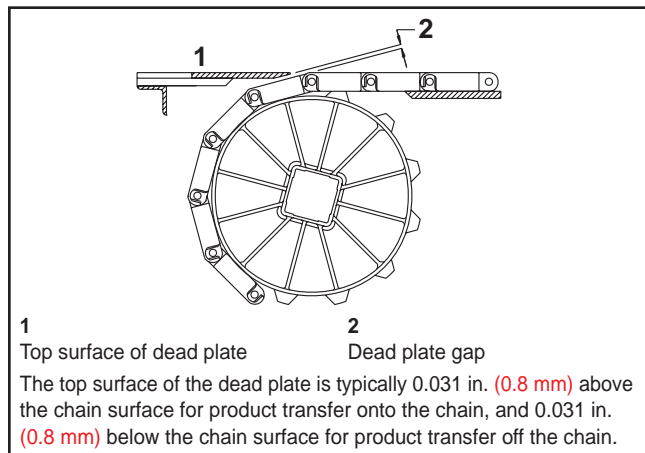

| Sprocket Description |     |           | Gap   |     |
|----------------------|-----|-----------|-------|-----|
| Pitch Diameter       |     | No. Teeth | in.   | mm  |
| in.                  | mm  |           |       |     |
| 6.0                  | 152 | 25        | 0.096 | 2.4 |



## Series 821 Straight Running Chain

|              |              |       |
|--------------|--------------|-------|
|              | in.          | mm    |
| Pitch, P     | 1.50         | 38.1  |
| Width, W     | 7.50         | 190.5 |
| Open Area    | 0%           |       |
| Hinge Style  | Closed       |       |
| Drive Method | Hinge-driven |       |

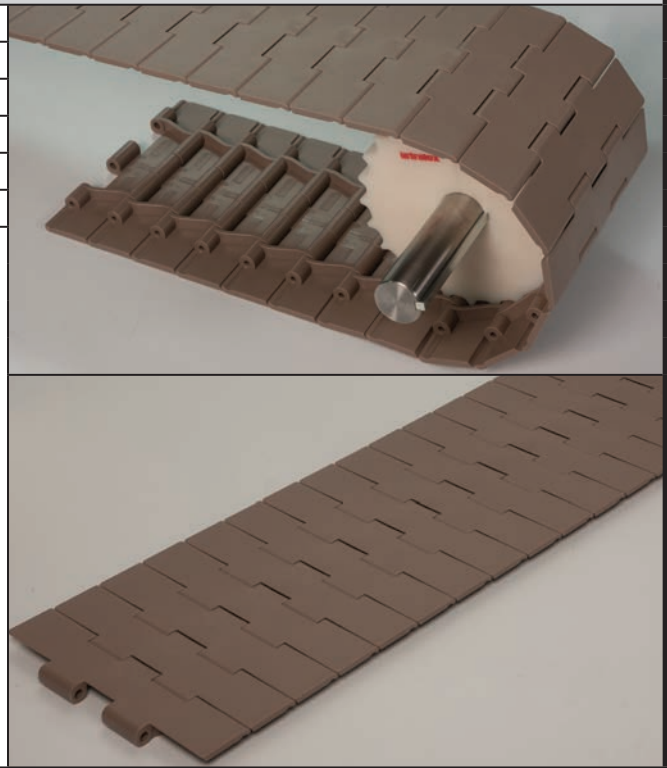
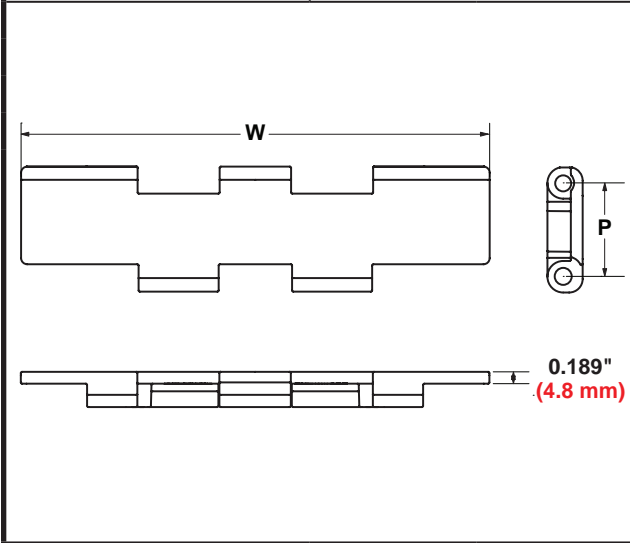

## Series 821 Straight Running Chain Data

| Chain Widths |       | Material          | Color | CS Chain Strength* |     | Temperature Range (continuous) |            | W Chain Weight |      |
|--------------|-------|-------------------|-------|--------------------|-----|--------------------------------|------------|----------------|------|
| in.          | mm    |                   |       | lb                 | kg  | °F                             | °C         | lb/ft          | kg/m |
| 7.50         | 190.5 | LF Acetal         | Brown | 625                | 283 | -40 to 176                     | -40 to 80  | 1.69           | 2.51 |
| 7.50         | 190.5 | Ultra Performance | Grey  | 625                | 283 | -40 to 248                     | -40 to 120 | 1.60           | 2.39 |

\*Working load.

## Series 821 Sprocket Data

| Number of Teeth | Nom. Pitch Diameter |     | Nom. Outer Diameter |     | Nom. Hub Width |    | Available Bore Sizes |       |              |       |
|-----------------|---------------------|-----|---------------------|-----|----------------|----|----------------------|-------|--------------|-------|
|                 |                     |     |                     |     |                |    | U.S. Sizes           |       | Metric Sizes |       |
|                 | in.                 | mm  | in.                 | mm  | in.            | mm | Round                | Round | Round        | Round |
| 25              | 6.0                 | 152 | 6.1                 | 154 | 3.1            | 80 | 1.25                 | 30    | 35           | 40    |



Drive Sprocket



Idler Sprocket

- **Drive sprockets vs. Idler sprockets:** generally, it is preferred to have a rotating idle shaft, so keyed "drive" sprockets would also be used to rotate the idle shaft in its bearings. If using a fixed idle shaft, use the "idler" sprockets, which have a looser bore and no keyway. A fixed idle shaft is suitable for speeds less than 100 fpm (30 mpm).
- If more than one chain is using the same idle shaft, only the sprocket for one chain should be locked in position. Generally use a keyed drive sprocket on the center most chain, to allow it to turn the shaft. The remaining sprockets will be the idler sprockets, locked using shaft collars to prevent side to side movement.

## Conveyor Frame Dimensions

Regardless of type or configuration, all conveyors using Intralox chains have some basic dimensional requirements. Specifically, dimensions “A”, “B”, “C” and “E” listed below should be implemented in any design.

For general applications and applications where end transfer of tip-sensitive product is not critical, use the “A” dimension at the bottom of the range.

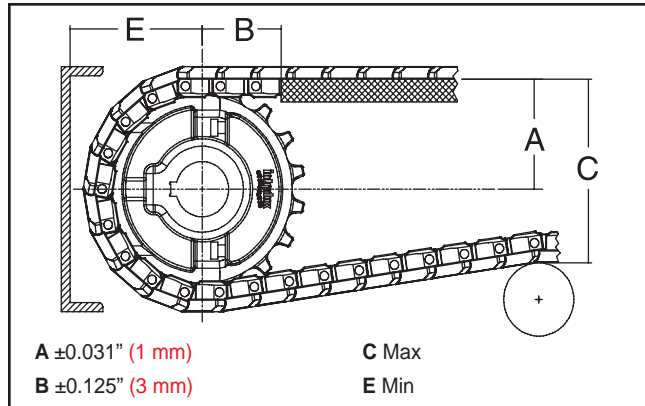

### SERIES 821

| Sprocket Description |     | A                     |           | B     |      | C   |      | E   |      |    |
|----------------------|-----|-----------------------|-----------|-------|------|-----|------|-----|------|----|
| Pitch Diameter       |     | Range (Bottom to Top) |           | in.   | mm   | in. | mm   | in. | mm   |    |
| in.                  | mm  | No. Teeth             | in.       |       |      |     |      |     |      | mm |
| 6.0                  | 152 | 25                    | 3.02-3.11 | 77-79 | 1.50 | 38  | 6.42 | 163 | 3.37 | 86 |

## Dead Plate Gap

Where there is a transfer point from a chain without finger transfer plates to a dead plate, there should be a gap between the surfaces to allow for the chordal action of the chain. As the chain engages its sprockets, chordal action causes the modules to move past a fixed point (the tip of the dead plate) with varying clearances. The table below shows the minimum amount of gap which occurs at the “low point” of the modules if the tip of the dead plate just comes in contact with the “high point” as the modules pass.

In some installations it may be desirable to keep the tip of the dead plate in contact with the chain, rather than allow a gap to occur. This can be done by hinging the mounting bracket for the dead plate. This allows the dead plate to move as the modules pass, but results in a small oscillating motion which may present tippage problems for sensitive containers or products.

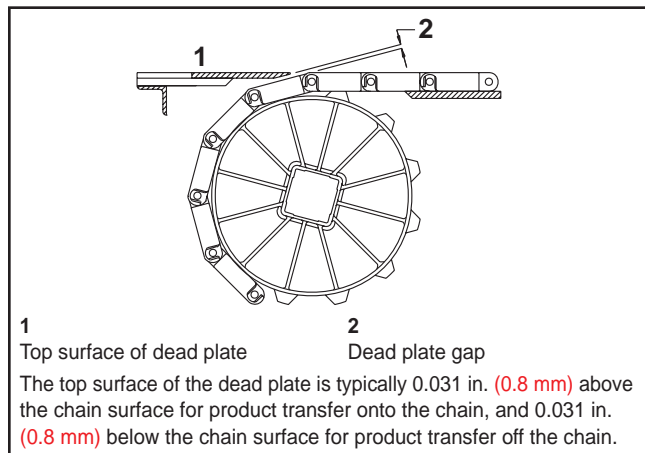

| Sprocket Description |     |           | Gap   |     |
|----------------------|-----|-----------|-------|-----|
| Pitch Diameter       |     | No. Teeth | in.   | mm  |
| in.                  | mm  |           |       |     |
| 6.0                  | 152 | 25        | 0.096 | 2.4 |

## Series 831 Straight Running Chain

|              |              |       |
|--------------|--------------|-------|
|              | in.          | mm    |
| Pitch, P     | 1.50         | 38.1  |
| Width, W     | 3.25         | 82.5  |
|              | 4.50         | 114.3 |
| Open Area    | 0%           |       |
| Hinge Style  | Closed       |       |
| Drive Method | Hinge-driven |       |

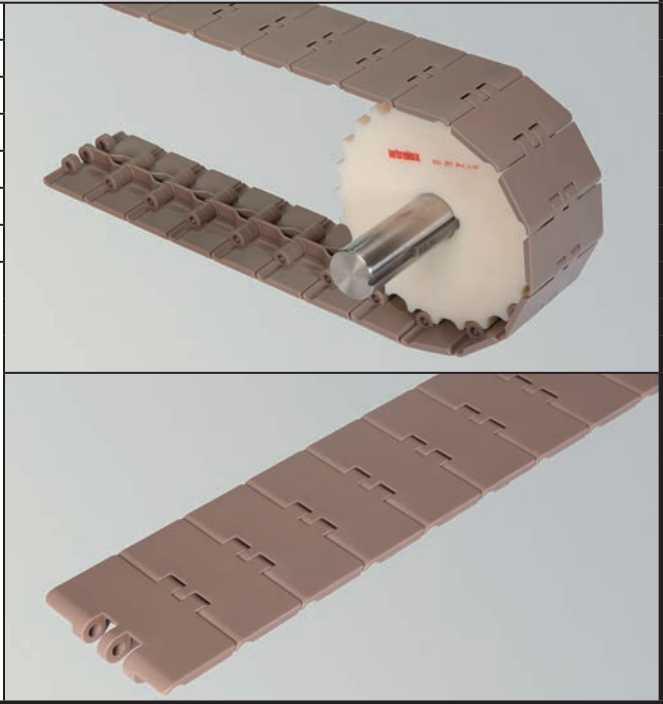
## Series 831 Straight Running Chain Data

| Chain Widths |       | Material          | Color | CS Chain Strength* |     | Temperature Range (continuous) |            | W Chain Weight |      |
|--------------|-------|-------------------|-------|--------------------|-----|--------------------------------|------------|----------------|------|
| in.          | mm    |                   |       | lb                 | kg  | °F                             | °C         | lb/ft          | kg/m |
| 3.25         | 82.5  | Ultra Performance | Grey  | 365                | 166 | -40 to 248                     | -40 to 120 | 0.61           | 0.90 |
| 4.50         | 114.3 | Ultra Performance | Grey  | 365                | 166 | -40 to 248                     | -40 to 120 | 0.62           | 0.92 |
| 3.25         | 82.5  | LF Acetal         | Brown | 365                | 166 | -40 to 176                     | -40 to 80  | 0.59           | 0.88 |
| 4.50         | 114.3 | LF Acetal         | Brown | 365                | 166 | -40 to 176                     | -40 to 80  | 0.72           | 1.07 |
| 7.50         | 190.5 | LF Acetal         | Brown | 365                | 166 | -40 to 176                     | -40 to 80  | 1.08           | 1.61 |

\*Working load.

## Series 831 Sprocket Data

| Number of Teeth | Nom. Pitch Diameter |     | Nom. Outer Diameter |     | Nom. Hub Width |    | Available Bore Sizes |    |              |    |
|-----------------|---------------------|-----|---------------------|-----|----------------|----|----------------------|----|--------------|----|
|                 |                     |     |                     |     |                |    | U.S. Sizes           |    | Metric Sizes |    |
|                 | in.                 | mm  | in.                 | mm  | in.            | mm | Round                |    | Round        |    |
| 25              | 6.0                 | 152 | 6.1                 | 154 | 2.3            | 59 | 1.25                 | 30 | 35           | 40 |

- **Drive sprockets vs. Idler sprockets:** generally, it is preferred to have a rotating idle shaft, so keyed "drive" sprockets would also be used to rotate the idle shaft in its bearings. If using a fixed idle shaft, use the "idler" sprockets, which have a looser bore and no keyway. A fixed idle shaft is suitable for speeds less than 100 fpm (30 mpm).
- If more than one chain is using the same idle shaft, only the sprocket for one chain should be locked in position. Generally use a keyed drive sprocket on the center most chain, to allow it to turn the shaft. The remaining sprockets will be the idler sprockets, locked using shaft collars to prevent side to side movement.



Drive Sprocket



Idler Sprocket

## Conveyor Frame Dimensions

Regardless of type or configuration, all conveyors using Intralox chains have some basic dimensional requirements. Specifically, dimensions "A", "B", "C" and "E" listed below should be implemented in any design.

For general applications and applications where end transfer of tip-sensitive product is not critical, use the "A" dimension at the bottom of the range.

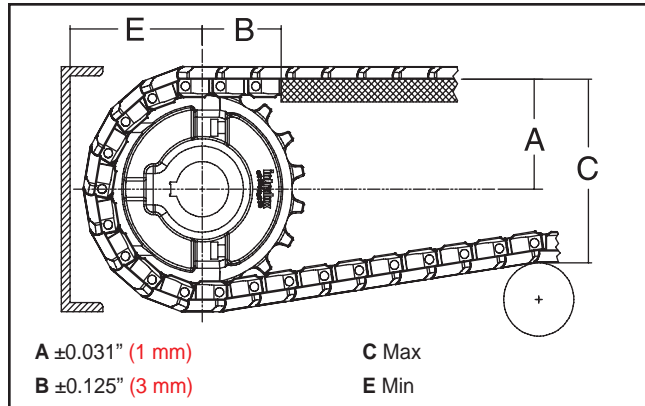

### SERIES 831

| Sprocket Description |     | A                     |           | B     |      | C   |      | E   |      |    |
|----------------------|-----|-----------------------|-----------|-------|------|-----|------|-----|------|----|
| Pitch Diameter       |     | Range (Bottom to Top) |           | in.   | mm   | in. | mm   | in. | mm   |    |
| in.                  | mm  | No. Teeth             | in.       |       |      |     |      |     |      | mm |
| 6.0                  | 152 | 25                    | 2.99-3.08 | 76-78 | 1.50 | 38  | 6.36 | 162 | 3.34 | 85 |

## Dead Plate Gap

Where there is a transfer point from a chain without finger transfer plates to a dead plate, there should be a gap between the surfaces to allow for the chordal action of the chain. As the chain engages its sprockets, chordal action causes the modules to move past a fixed point (the tip of the dead plate) with varying clearances. The table below shows the minimum amount of gap which occurs at the "low point" of the modules if the tip of the dead plate just comes in contact with the "high point" as the modules pass.

In some installations it may be desirable to keep the tip of the dead plate in contact with the chain, rather than allow a gap to occur. This can be done by hinging the mounting bracket for the dead plate. This allows the dead plate to move as the modules pass, but results in a small oscillating motion which may present tippage problems for sensitive containers or products.

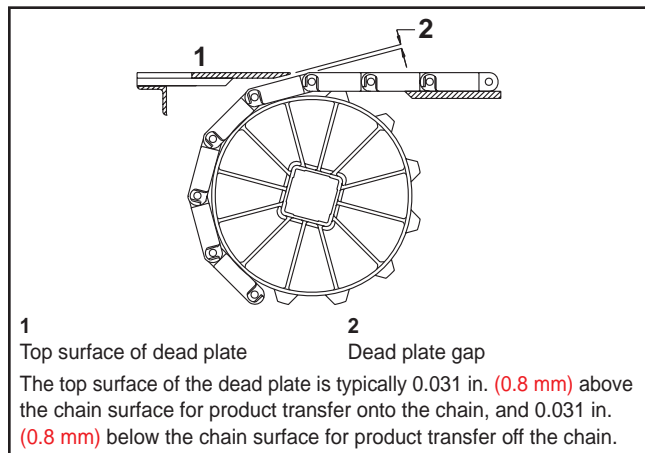

| Sprocket Description |     |           | Gap   |     |
|----------------------|-----|-----------|-------|-----|
| Pitch Diameter       |     | No. Teeth | in.   | mm  |
| in.                  | mm  |           |       |     |
| 6.0                  | 152 | 25        | 0.096 | 2.4 |

## Series 878 Sideflexing Chain with Tab

|              |              |      |
|--------------|--------------|------|
|              | in.          | mm   |
| Pitch, P     | 1.50         | 38.1 |
| Width, W     | 3.25         | 82.5 |
| Open Area    | 0%           |      |
| Hinge Style  | Closed       |      |
| Drive Method | Hinge-driven |      |

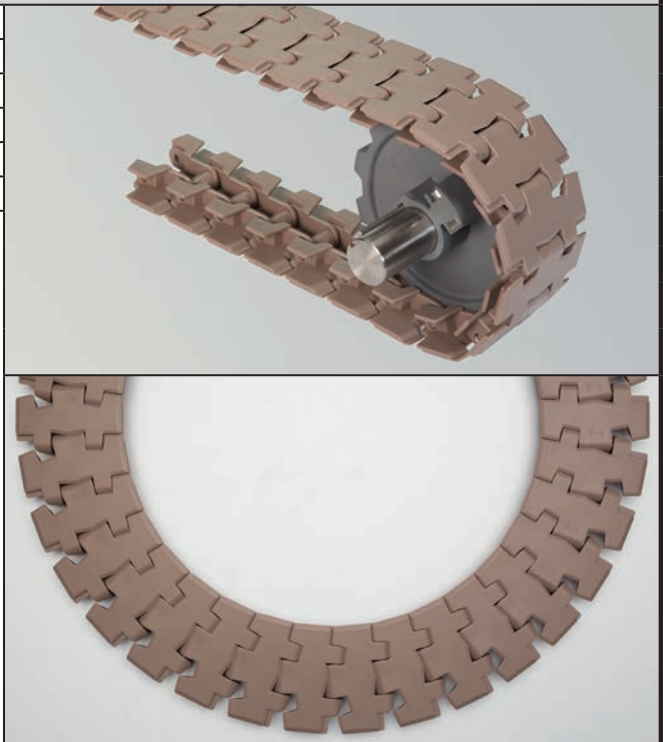
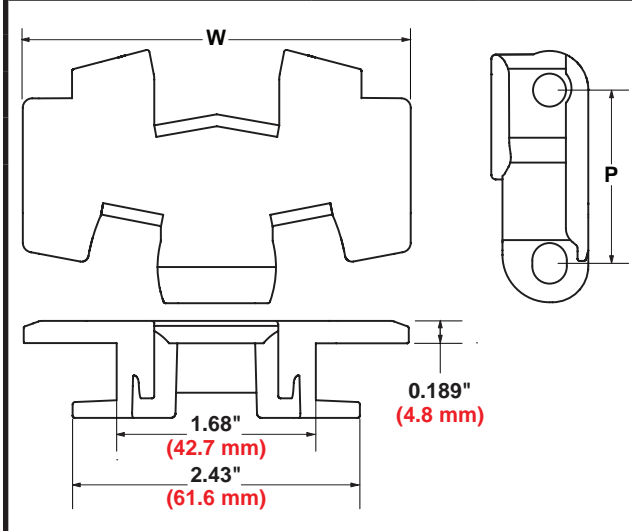

## Series 878 Sideflexing Chain with Tab Data

| Chain Widths |      | Material  | Color | Centerline Radius |     | CS Chain Strength* |     | Temperature Range (continuous) |           | W Chain Weight |      |
|--------------|------|-----------|-------|-------------------|-----|--------------------|-----|--------------------------------|-----------|----------------|------|
| in.          | mm   |           |       | in.               | mm  | lb                 | kg  | °F                             | °C        | lb/ft          | kg/m |
| 3.25         | 82.5 | LF Acetal | Brown | 7.875             | 200 | 425                | 193 | -40 to 176                     | -40 to 80 | 0.71           | 1.06 |

\*Working load.

## Series 878/879/880 Sprocket Data

| Number of Teeth | Nom. Pitch Diameter |     | Nom. Outer Diameter |     | Nom. Hub Width |    | Available Bore Sizes |       |              |       |
|-----------------|---------------------|-----|---------------------|-----|----------------|----|----------------------|-------|--------------|-------|
|                 | in.                 | mm  | in.                 | mm  | in.            | mm | U.S. Sizes           |       | Metric Sizes |       |
|                 |                     |     |                     |     |                |    | Round                | Round | Round        | Round |
| 12              | 5.8                 | 147 | 5.8                 | 148 | 2.3            | 59 | 1.25                 | 30    | 35           | 40    |



Drive Sprocket



Idler Sprocket

- **Drive sprockets vs. Idler sprockets:** generally, it is preferred to have a rotating idle shaft, so keyed "drive" sprockets would also be used to rotate the idle shaft in its bearings. If using a fixed idle shaft, use the "idler" sprockets, which have a looser bore and no keyway. A fixed idle shaft is suitable for speeds less than 100 fpm (30 mpm).
- If more than one chain is using the same idle shaft, only the sprocket for one chain should be locked in position. Generally use a keyed drive sprocket on the center most chain, to allow it to turn the shaft. The remaining sprockets will be the idler sprockets, locked using shaft collars to prevent side to side movement.

## Conveyor Frame Dimensions

Regardless of type or configuration, all conveyors using Intralox chains have some basic dimensional requirements. Specifically, dimensions “A”, “B”, “C” and “E” listed below should be implemented in any design.

For general applications and applications where end transfer of tip-sensitive product is not critical, use the “A” dimension at the bottom of the range.

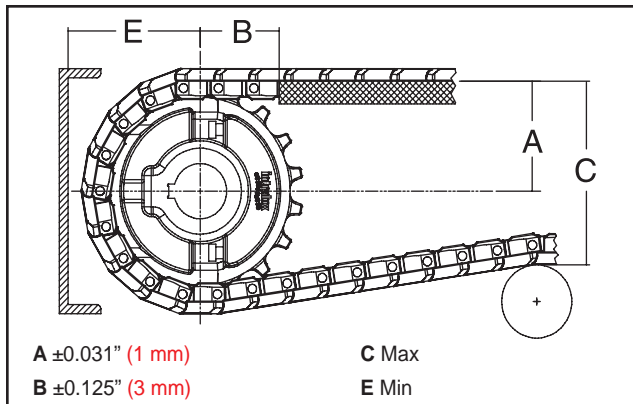

### SERIES 878

| Sprocket Description |     | A                     |           | B     |      | C   |      | E   |      |    |
|----------------------|-----|-----------------------|-----------|-------|------|-----|------|-----|------|----|
| Pitch Diameter       |     | Range (Bottom to Top) |           | in.   | mm   | in. | mm   | in. | mm   |    |
| in.                  | mm  | No. Teeth             | in.       |       |      |     |      |     |      | mm |
| 5.8                  | 147 | 12                    | 2.94-3.04 | 75-77 | 1.50 | 38  | 6.27 | 159 | 3.29 | 84 |

## Dead Plate Gap

Where there is a transfer point from a chain without finger transfer plates to a dead plate, there should be a gap between the surfaces to allow for the chordal action of the chain. As the chain engages its sprockets, chordal action causes the modules to move past a fixed point (the tip of the dead plate) with varying clearances. The table below shows the minimum amount of gap which occurs at the “low point” of the modules if the tip of the dead plate just comes in contact with the “high point” as the modules pass.

In some installations it may be desirable to keep the tip of the dead plate in contact with the chain, rather than allow a gap to occur. This can be done by hinging the mounting bracket for the dead plate. This allows the dead plate to move as the modules pass, but results in a small oscillating motion which may present tippage problems for sensitive containers or products.

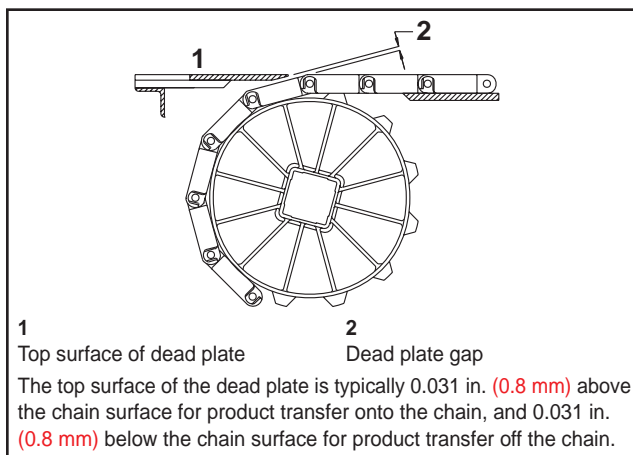

| Sprocket Description |     |           | Gap   |     |
|----------------------|-----|-----------|-------|-----|
| Pitch Diameter       |     | No. Teeth | in.   | mm  |
| in.                  | mm  |           |       |     |
| 5.8                  | 147 | 12        | 0.099 | 2.5 |

## Series 879 Sideflexing Chain with Tab

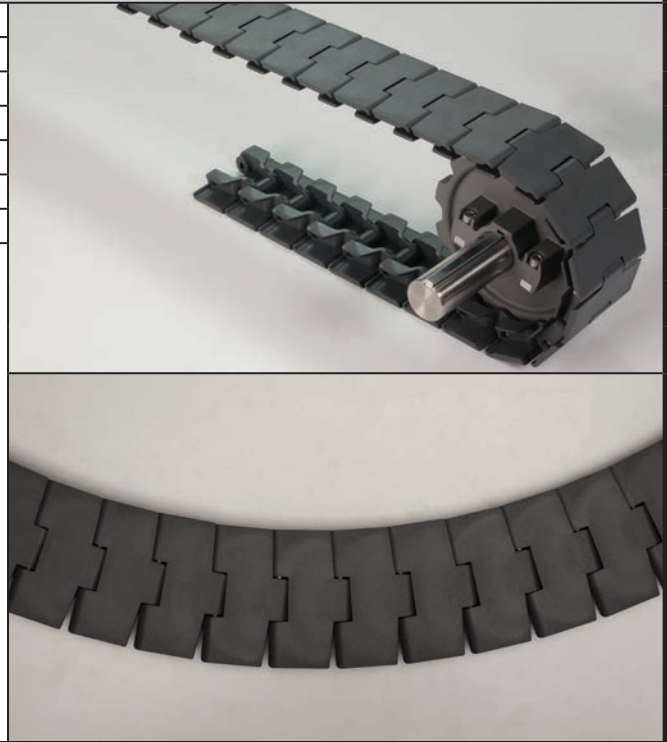
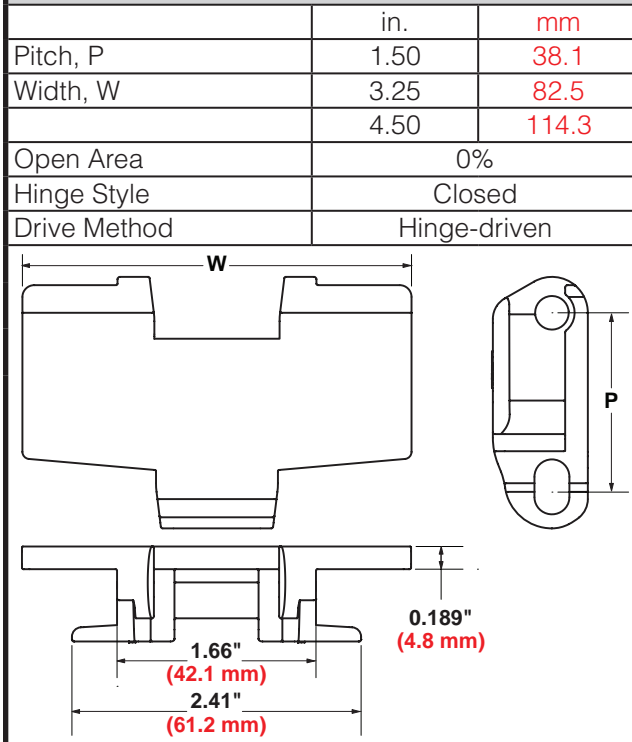

## Series 879 Sideflexing Chain with Tab Data

| Chain Widths |       | Material          | Color | Centerline Radius |     | CS Chain Strength* |     | Temperature Range (continuous) |            | W Chain Weight |      |
|--------------|-------|-------------------|-------|-------------------|-----|--------------------|-----|--------------------------------|------------|----------------|------|
| in.          | mm    |                   |       | in.               | mm  | lb                 | kg  | °F                             | °C         | lb/ft          | kg/m |
| 3.25         | 82.5  | Ultra Performance | Grey  | 18                | 457 | 425                | 193 | -40 to 248                     | -40 to 120 | 0.67           | 1.00 |
| 4.50         | 114.3 | Ultra Performance | Grey  | 24                | 610 | 425                | 193 | -40 to 248                     | -40 to 120 | 0.78           | 1.15 |
| 3.25         | 82.5  | LF Acetal         | Brown | 18                | 457 | 425                | 193 | -40 to 176                     | -40 to 80  | 0.71           | 1.06 |
| 4.50         | 114.3 | LF Acetal         | Brown | 24                | 610 | 425                | 193 | -40 to 176                     | -40 to 80  | 0.83           | 1.24 |

\*Working load.

## Series 878/879/880 Sprocket Data

| Number of Teeth | Nom. Pitch Diameter |     | Nom. Outer Diameter |     | Nom. Hub Width |    | Available Bore Sizes |    |              |    |
|-----------------|---------------------|-----|---------------------|-----|----------------|----|----------------------|----|--------------|----|
|                 |                     |     |                     |     |                |    | U.S. Sizes           |    | Metric Sizes |    |
|                 | in.                 | mm  | in.                 | mm  | in.            | mm | Round                |    | Round        |    |
| 12              | 5.8                 | 147 | 5.8                 | 148 | 2.3            | 59 | 1.25                 | 30 | 35           | 40 |



Drive Sprocket



Idler Sprocket

- **Drive sprockets vs. Idler sprockets:** generally, it is preferred to have a rotating idle shaft, so keyed "drive" sprockets would also be used to rotate the idle shaft in its bearings. If using a fixed idle shaft, use the "idler" sprockets, which have a looser bore and no keyway. A fixed idle shaft is suitable for speeds less than 100 fpm (30 rpm).
- If more than one chain is using the same idle shaft, only the sprocket for one chain should be locked in position. Generally use a keyed drive sprocket on the center most chain, to allow it to turn the shaft. The remaining sprockets will be the idler sprockets, locked using shaft collars to prevent side to side movement.

## Conveyor Frame Dimensions

Regardless of type or configuration, all conveyors using Intralox chains have some basic dimensional requirements. Specifically, dimensions “A”, “B”, “C” and “E” listed below should be implemented in any design.

For general applications and applications where end transfer of tip-sensitive product is not critical, use the “A” dimension at the bottom of the range.

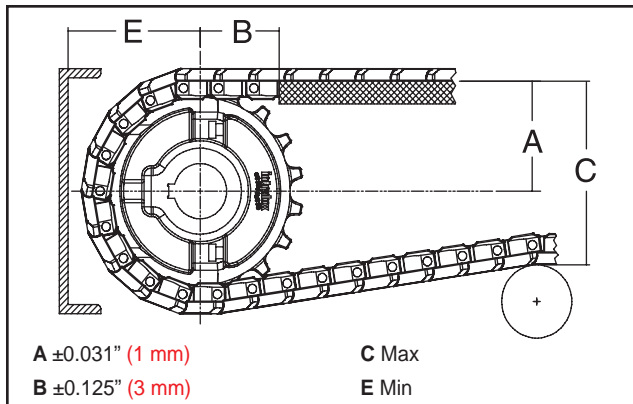

### SERIES 879

| Sprocket Description |     | A                     |           | B     |      | C   |      | E   |      |    |
|----------------------|-----|-----------------------|-----------|-------|------|-----|------|-----|------|----|
| Pitch Diameter       |     | Range (Bottom to Top) |           | in.   | mm   | in. | mm   | in. | mm   |    |
| in.                  | mm  | No. Teeth             | in.       |       |      |     |      |     |      | mm |
| 5.8                  | 147 | 12                    | 2.93-3.03 | 74-77 | 1.50 | 38  | 6.24 | 158 | 3.28 | 83 |

## Dead Plate Gap

Where there is a transfer point from a chain without finger transfer plates to a dead plate, there should be a gap between the surfaces to allow for the chordal action of the chain. As the chain engages its sprockets, chordal action causes the modules to move past a fixed point (the tip of the dead plate) with varying clearances. The table below shows the minimum amount of gap which occurs at the “low point” of the modules if the tip of the dead plate just comes in contact with the “high point” as the modules pass.

In some installations it may be desirable to keep the tip of the dead plate in contact with the chain, rather than allow a gap to occur. This can be done by hinging the mounting bracket for the dead plate. This allows the dead plate to move as the modules pass, but results in a small oscillating motion which may present tippage problems for sensitive containers or products.

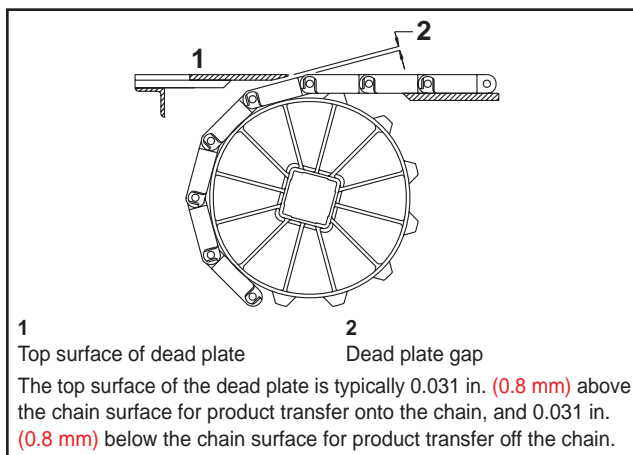

| Sprocket Description |     |           | Gap   |     |
|----------------------|-----|-----------|-------|-----|
| Pitch Diameter       |     | No. Teeth | in.   | mm  |
| in.                  | mm  |           |       |     |
| 5.8                  | 147 | 12        | 0.099 | 2.5 |



## Series 880 Sideflexing Chain with Tab

|              |              |       |
|--------------|--------------|-------|
|              | in.          | mm    |
| Pitch, P     | 1.50         | 38.1  |
| Width, W     | 3.25         | 82.5  |
|              | 4.50         | 114.3 |
| Open Area    | 0%           |       |
| Hinge Style  | Closed       |       |
| Drive Method | Hinge-driven |       |

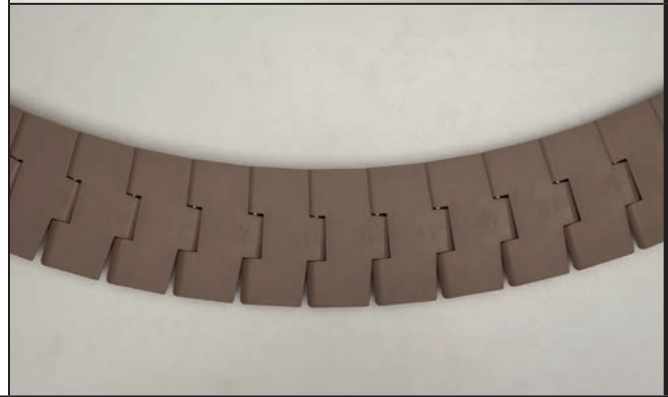
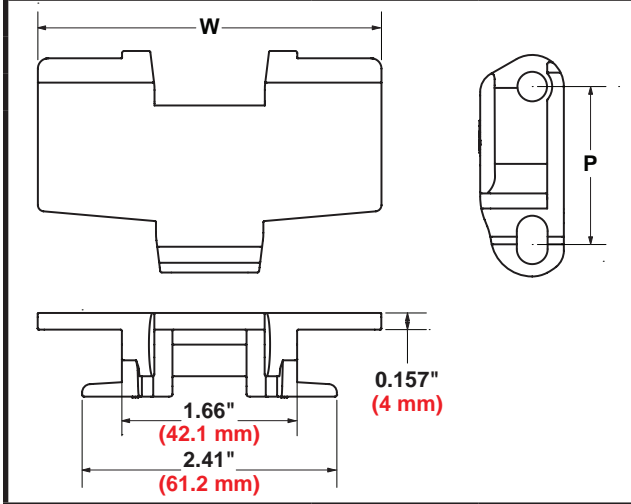
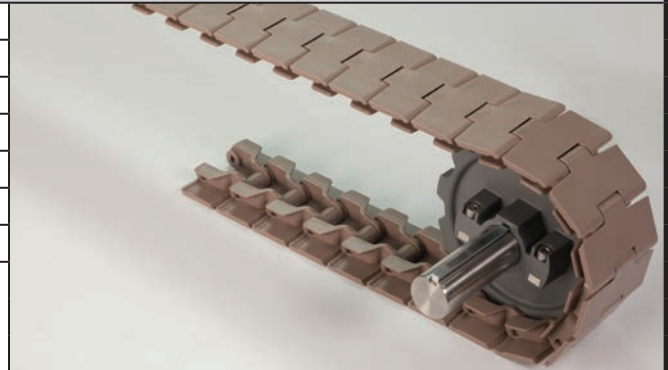

## Series 880 Sideflexing Chain with Tab Data

| Chain Widths |       | Material  | Color | Centerline Radius |     | <b>CS</b> Chain Strength* |     | Temperature Range (continuous) |           | <b>W</b> Chain Weight |      |
|--------------|-------|-----------|-------|-------------------|-----|---------------------------|-----|--------------------------------|-----------|-----------------------|------|
| in.          | mm    |           |       | in.               | mm  | lb                        | kg  | °F                             | °C        | lb/ft                 | kg/m |
| 3.25         | 82.5  | LF Acetal | Brown | 18                | 457 | 425                       | 193 | -40 to 176                     | -40 to 80 | 0.68                  | 1.02 |
| 4.50         | 114.3 | LF Acetal | Brown | 24                | 610 | 425                       | 193 | -40 to 176                     | -40 to 80 | 0.77                  | 1.15 |

\*Working load.

## Series 878/879/880 Sprocket Data

| Number of Teeth | Nom. Pitch Diameter |     | Nom. Outer Diameter |     | Nom. Hub Width |    | Available Bore Sizes |       |              |       |
|-----------------|---------------------|-----|---------------------|-----|----------------|----|----------------------|-------|--------------|-------|
|                 |                     |     |                     |     |                |    | U.S. Sizes           |       | Metric Sizes |       |
|                 | in.                 | mm  | in.                 | mm  | in.            | mm | Round                | Round | Round        | Round |
| 12              | 5.8                 | 147 | 5.8                 | 148 | 2.3            | 59 | 1.25                 | 30    | 35           | 40    |



Drive Sprocket



Idler Sprocket

- **Drive sprockets vs. Idler sprockets:** generally, it is preferred to have a rotating idle shaft, so keyed "drive" sprockets would also be used to rotate the idle shaft in its bearings. If using a fixed idle shaft, use the "idler" sprockets, which have a looser bore and no keyway. A fixed idle shaft is suitable for speeds less than 100 fpm (30 mpm).
- If more than one chain is using the same idle shaft, only the sprocket for one chain should be locked in position. Generally use a keyed drive sprocket on the center most chain, to allow it to turn the shaft. The remaining sprockets will be the idler sprockets, locked using shaft collars to prevent side to side movement.

## Series 880 Sideflexing Magnetic Chain

|              |              |      |
|--------------|--------------|------|
|              | in.          | mm   |
| Pitch, P     | 1.50         | 38.1 |
| Width, W     | 3.25         | 82.5 |
| Open Area    | 0%           |      |
| Hinge Style  | Closed       |      |
| Drive Method | Hinge-driven |      |

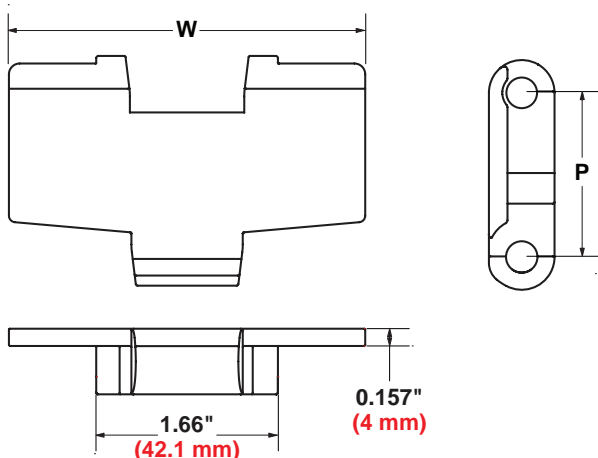
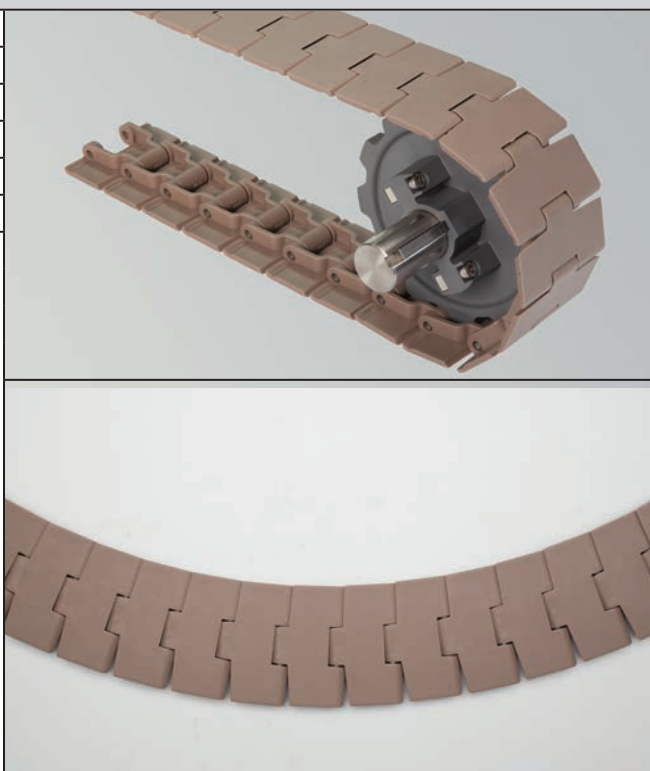

## Series 880 Sideflexing Magnetic Chain Data

| Chain Widths |      | Material  | Color | Centerline Radius |     | CS Chain Strength* |     | Temperature Range (continuous) |           | W Chain Weight |      |
|--------------|------|-----------|-------|-------------------|-----|--------------------|-----|--------------------------------|-----------|----------------|------|
| in.          | mm   |           |       | in.               | mm  | lb                 | kg  | °F                             | °C        | lb/ft          | kg/m |
| 3.25         | 82.5 | LF Acetal | Brown | 18                | 457 | 425                | 193 | -40 to 176                     | -40 to 80 | 0.636          | 0.95 |

\*Working load.

## Series 878/879/880 Sprocket Data

| Number of Teeth | Nom. Pitch Diameter |     | Nom. Outer Diameter |     | Nom. Hub Width |    | Available Bore Sizes |    |              |    |
|-----------------|---------------------|-----|---------------------|-----|----------------|----|----------------------|----|--------------|----|
|                 |                     |     |                     |     |                |    | U.S. Sizes           |    | Metric Sizes |    |
|                 | in.                 | mm  | in.                 | mm  | in.            | mm | Round                |    | Round        |    |
| 12              | 5.8                 | 147 | 5.8                 | 148 | 2.3            | 59 | 1.25                 | 30 | 35           | 40 |



Drive Sprocket



Idler Sprocket

- **Drive sprockets vs. Idler sprockets:** generally, it is preferred to have a rotating idle shaft, so keyed "drive" sprockets would also be used to rotate the idle shaft in its bearings. If using a fixed idle shaft, use the "idler" sprockets, which have a looser bore and no keyway. A fixed idle shaft is suitable for speeds less than 100 fpm (30 mpm).
- If more than one chain is using the same idle shaft, only the sprocket for one chain should be locked in position. Generally use a keyed drive sprocket on the center most chain, to allow it to turn the shaft. The remaining sprockets will be the idler sprockets, locked using shaft collars to prevent side to side movement.

## Conveyor Frame Dimensions

Regardless of type or configuration, all conveyors using Intralox chains have some basic dimensional requirements. Specifically, dimensions “A”, “B”, “C” and “E” listed below should be implemented in any design.

For general applications and applications where end transfer of tip-sensitive product is not critical, use the “A” dimension at the bottom of the range.

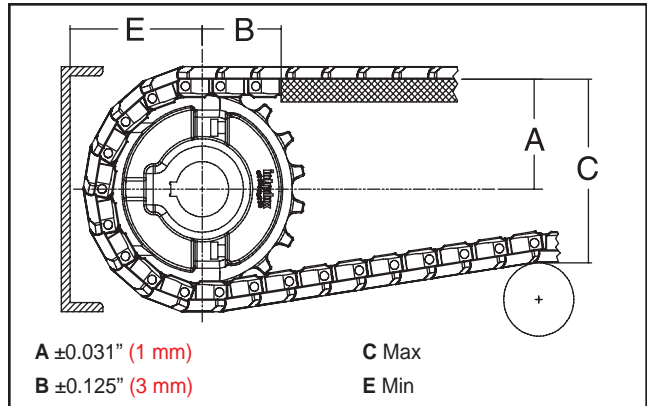

| SERIES 880           |     |           |                       |       |      |    |      |     |      |    |
|----------------------|-----|-----------|-----------------------|-------|------|----|------|-----|------|----|
| Sprocket Description |     |           | A                     |       | B    |    | C    |     | E    |    |
| Pitch Diameter       |     | No. Teeth | Range (Bottom to Top) |       | in.  | mm | in.  | mm  | in.  | mm |
| in.                  | mm  |           | in.                   | mm    |      |    |      |     |      |    |
| 5.8                  | 147 | 12        | 2.93-3.03             | 74-77 | 1.50 | 38 | 6.22 | 158 | 3.25 | 83 |

## Dead Plate Gap

Where there is a transfer point from a chain without finger transfer plates to a dead plate, there should be a gap between the surfaces to allow for the chordal action of the chain. As the chain engages its sprockets, chordal action causes the modules to move past a fixed point (the tip of the dead plate) with varying clearances. The table below shows the minimum amount of gap which occurs at the “low point” of the modules if the tip of the dead plate just comes in contact with the “high point” as the modules pass.

In some installations it may be desirable to keep the tip of the dead plate in contact with the chain, rather than allow a gap to occur. This can be done by hinging the mounting bracket for the dead plate. This allows the dead plate to move as the modules pass, but results in a small oscillating motion which may present tippage problems for sensitive containers or products.

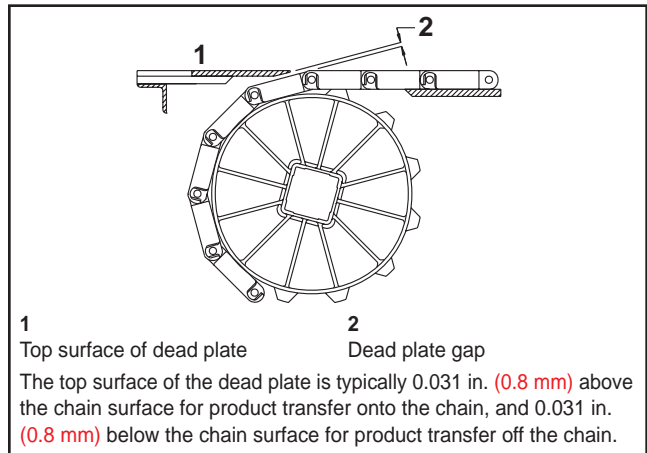

| Sprocket Description |     |           | Gap   |     |
|----------------------|-----|-----------|-------|-----|
| Pitch Diameter       |     | No. Teeth | in.   | mm  |
| in.                  | mm  |           |       |     |
| 5.8                  | 147 | 12        | 0.099 | 2.5 |

**Section 3**

**882**

## Series 882 Sideflexing Chain with Tab

|              |              |       |
|--------------|--------------|-------|
|              | in.          | mm    |
| Pitch, P     | 1.50         | 38.1  |
| Width, W     | 4.50         | 114.3 |
|              | 7.50         | 190.5 |
|              | 12.00        | 304.8 |
| Open Area    | 0%           |       |
| Hinge Style  | Closed       |       |
| Drive Method | Hinge-driven |       |

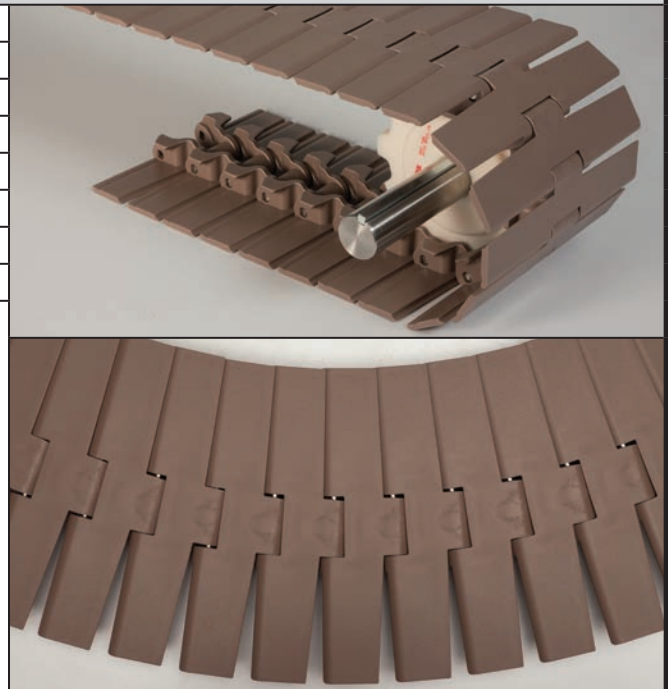
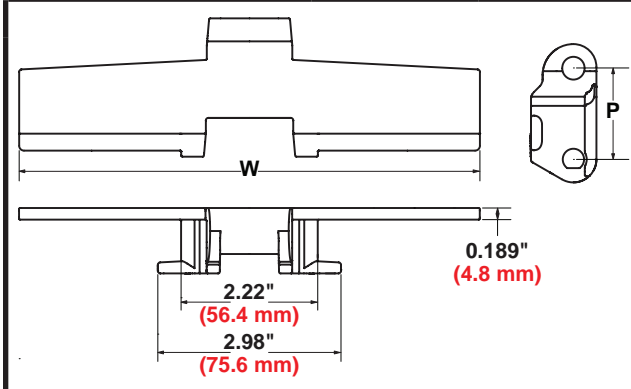

## Series 882 Sideflexing Chain with Tab Data

| Chain Widths |       | Material          | Color | Centerline Radius |     | CS Chain Strength* |     | Temperature Range (continuous) |            | W Chain Weight |      |
|--------------|-------|-------------------|-------|-------------------|-----|--------------------|-----|--------------------------------|------------|----------------|------|
| in.          | mm    |                   |       | in.               | mm  | lb                 | kg  | °F                             | °C         | lb/ft          | kg/m |
| 4.50         | 114.3 | LF Acetal         | Brown | 24                | 610 | 625                | 283 | -40 to 176                     | -40 to 80  | 1.24           | 1.85 |
| 4.50         | 114.3 | Ultra Performance | Grey  | 24                | 610 | 625                | 283 | -40 to 248                     | -40 to 120 | 1.19           | 1.78 |
| 7.50         | 190.5 | LF Acetal         | Brown | 24                | 610 | 625                | 283 | -40 to 176                     | -40 to 80  | 1.54           | 2.28 |
| 7.50         | 190.5 | Ultra Performance | Grey  | 24                | 610 | 625                | 283 | -40 to 248                     | -40 to 120 | 1.49           | 2.22 |
| 12.00        | 304.8 | LF Acetal         | Brown | 24                | 610 | 625                | 283 | -40 to 176                     | -40 to 80  | 1.94           | 2.88 |

\*Working load.

## Series 882 Sprocket Data

| Number of Teeth | Nom. Pitch Diameter |     | Nom. Outer Diameter |     | Nom. Hub Width |    | Available Bore Sizes |    |              |    |
|-----------------|---------------------|-----|---------------------|-----|----------------|----|----------------------|----|--------------|----|
|                 |                     |     |                     |     |                |    | U.S. Sizes           |    | Metric Sizes |    |
|                 | in.                 | mm  | in.                 | mm  | in.            | mm | Round                |    | Round        |    |
| 12              | 5.8                 | 147 | 5.8                 | 148 | 1.7            | 43 | 1.25                 | 30 | 35           | 40 |



Drive Sprocket

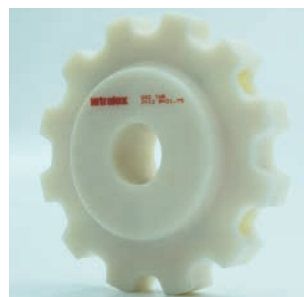

Idler Sprocket

- **Drive sprockets vs. Idler sprockets:** generally, it is preferred to have a rotating idle shaft, so keyed "drive" sprockets would also be used to rotate the idle shaft in its bearings. If using a fixed idle shaft, use the "idler" sprockets, which have a looser bore and no keyway. A fixed idle shaft is suitable for speeds less than 100 fpm (30 mpm).
- If more than one chain is using the same idle shaft, only the sprocket for one chain should be locked in position. Generally use a keyed drive sprocket on the center most chain, to allow it to turn the shaft. The remaining sprockets will be the idler sprockets, locked using shaft collars to prevent side to side movement.

## Conveyor Frame Dimensions

Regardless of type or configuration, all conveyors using Intralox chains have some basic dimensional requirements. Specifically, dimensions “A”, “B”, “C” and “E” listed below should be implemented in any design.

For general applications and applications where end transfer of tip-sensitive product is not critical, use the “A” dimension at the bottom of the range.

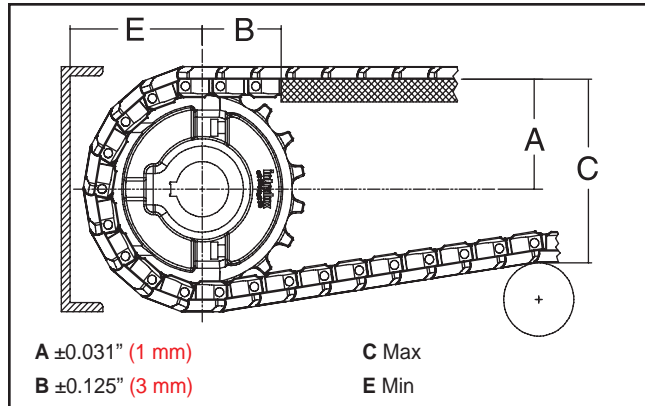

| SERIES 882           |     |           |                       |       |      |    |      |     |      |    |
|----------------------|-----|-----------|-----------------------|-------|------|----|------|-----|------|----|
| Sprocket Description |     |           | A                     |       | B    |    | C    |     | E    |    |
| Pitch Diameter       |     | No. Teeth | Range (Bottom to Top) |       | in.  | mm | in.  | mm  | in.  | mm |
| in.                  | mm  |           | in.                   | mm    |      |    |      |     |      |    |
| 5.8                  | 147 | 12        | 2.96-3.06             | 75-78 | 1.50 | 38 | 6.32 | 161 | 3.32 | 84 |

## Dead Plate Gap

Where there is a transfer point from a chain without finger transfer plates to a dead plate, there should be a gap between the surfaces to allow for the chordal action of the chain. As the chain engages its sprockets, chordal action causes the modules to move past a fixed point (the tip of the dead plate) with varying clearances. The table below shows the minimum amount of gap which occurs at the “low point” of the modules if the tip of the dead plate just comes in contact with the “high point” as the modules pass.

In some installations it may be desirable to keep the tip of the dead plate in contact with the chain, rather than allow a gap to occur. This can be done by hinging the mounting bracket for the dead plate. This allows the dead plate to move as the modules pass, but results in a small oscillating motion which may present tippage problems for sensitive containers or products.

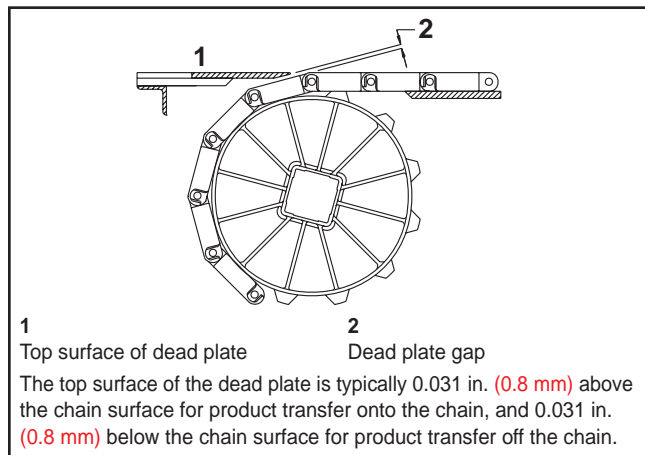

| Sprocket Description |     |           | Gap   |     |
|----------------------|-----|-----------|-------|-----|
| Pitch Diameter       |     | No. Teeth | in.   | mm  |
| in.                  | mm  |           |       |     |
| 5.8                  | 147 | 12        | 0.099 | 2.5 |

## Series 1060 Sideflexing Magnetic Chain

|              |              |      |
|--------------|--------------|------|
|              | in.          | mm   |
| Pitch, P     | 1.00         | 25.4 |
| Width, W     | 3.30         | 83.8 |
| Open Area    | 0%           |      |
| Hinge Style  | Closed       |      |
| Drive Method | Hinge-driven |      |

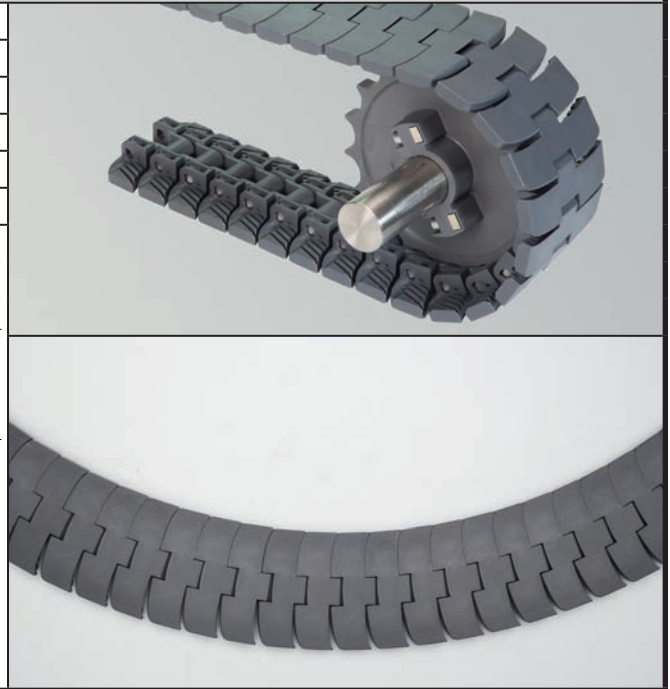
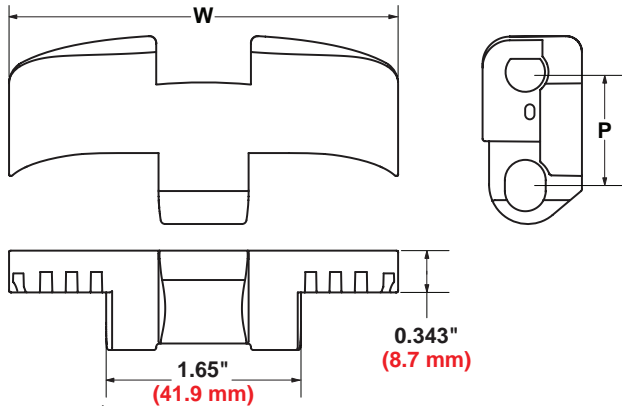

## Series 1060 Sideflexing Magnetic Chain Data

| Chain Widths |      | Material          | Color | Centerline Radius |     | CS Chain Strength* |     | Temperature Range (continuous) |            | W Chain Weight |      |
|--------------|------|-------------------|-------|-------------------|-----|--------------------|-----|--------------------------------|------------|----------------|------|
| in.          | mm   |                   |       | in.               | mm  | lb                 | kg  | °F                             | °C         | lb/ft          | kg/m |
| 3.30         | 83.8 | Ultra Performance | Grey  | 19.7              | 500 | 425                | 193 | -40 to 248                     | -40 to 120 | 1.014          | 1.51 |

\*Working load.

## Series 1060 Sprocket Data

| Number of Teeth | Nom. Pitch Diameter |     | Nom. Outer Diameter |     | Nom. Hub Width |    | Available Bore Sizes |              |    |
|-----------------|---------------------|-----|---------------------|-----|----------------|----|----------------------|--------------|----|
|                 |                     |     |                     |     |                |    | U.S. Sizes           | Metric Sizes |    |
|                 | in.                 | mm  | in.                 | mm  | in.            | mm | Round                | Round        |    |
| 18              | 5.8                 | 147 | 5.8                 | 147 | 1.8            | 46 | 1.25                 | 1.50         | 40 |



Drive Sprocket



Idler Sprocket

- **Drive sprockets vs. Idler sprockets:** generally, it is preferred to have a rotating idle shaft, so keyed "drive" sprockets would also be used to rotate the idle shaft in its bearings. If using a fixed idle shaft, use the "idler" sprockets, which have a looser bore and no keyway. A fixed idle shaft is suitable for speeds less than 100 fpm (30 mpm).
- If more than one chain is using the same idle shaft, only the sprocket for one chain should be locked in position. Generally use a keyed drive sprocket on the center most chain, to allow it to turn the shaft. The remaining sprockets will be the idler sprockets, locked using shaft collars to prevent side to side movement.

## Conveyor Frame Dimensions

Regardless of type or configuration, all conveyors using Intralox chains have some basic dimensional requirements. Specifically, dimensions “A”, “B”, “C” and “E” listed below should be implemented in any design.

For general applications and applications where end transfer of tip-sensitive product is not critical, use the “A” dimension at the bottom of the range.

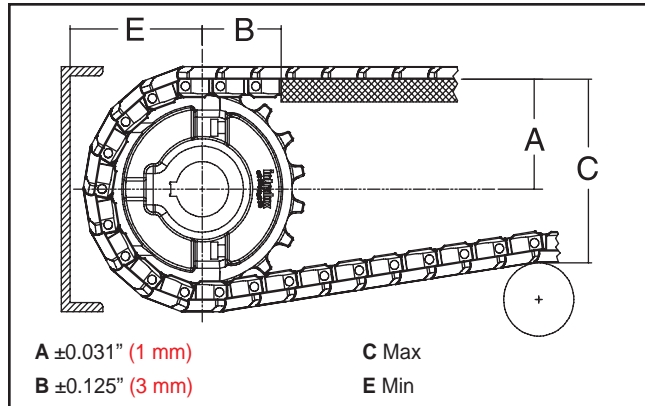

| SERIES 1060          |     |           |                       |       |      |    |      |     |      |    |
|----------------------|-----|-----------|-----------------------|-------|------|----|------|-----|------|----|
| Sprocket Description |     | A         |                       | B     |      | C  |      | E   |      |    |
| Pitch Diameter       |     | No. Teeth | Range (Bottom to Top) |       | in.  | mm | in.  | mm  | in.  | mm |
| in.                  | mm  |           | in.                   | mm    |      |    |      |     |      |    |
| 5.8                  | 147 | 18        | 2.98-3.03             | 76-77 | 1.00 | 25 | 6.40 | 163 | 3.43 | 87 |

## Dead Plate Gap

Where there is a transfer point from a chain without finger transfer plates to a dead plate, there should be a gap between the surfaces to allow for the chordal action of the chain. As the chain engages its sprockets, chordal action causes the modules to move past a fixed point (the tip of the dead plate) with varying clearances. The table below shows the minimum amount of gap which occurs at the “low point” of the modules if the tip of the dead plate just comes in contact with the “high point” as the modules pass.

In some installations it may be desirable to keep the tip of the dead plate in contact with the chain, rather than allow a gap to occur. This can be done by hinging the mounting bracket for the dead plate. This allows the dead plate to move as the modules pass, but results in a small oscillating motion which may present tippage problems for sensitive containers or products.

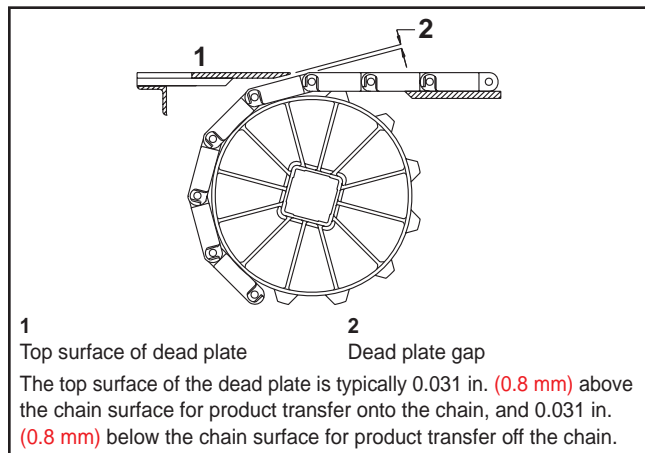

| Sprocket Description |     |           | Gap   |     |
|----------------------|-----|-----------|-------|-----|
| Pitch Diameter       |     | No. Teeth | in.   | mm  |
| in.                  | mm  |           |       |     |
| 5.8                  | 147 | 18        | 0.043 | 1.1 |



## BASIC DESIGN ELEMENTS

- **Sprockets and shafts:** Selected based on transfer dimensions, speed, and torque requirements.
- **Carryway (conveying surface):** Chains can generally run in a “track.” Track can be made from a single piece, or built from multiple pieces, depending on which will allow for smoother chain operation and better product support.
- **Returnway (return path):** Chains can also be returned in a track. For straight chains, a simple roller return system or sliding bed can be used.

Regardless of type or configuration, all conveyors using Intralox chains have some basic dimensional requirements. Specifically, dimensions “A”, “B”, “C”, and “E” in the illustrations and tables below should be implemented in any design. Also, the conveyor should allow access to the side of the chain at some point for rod clearance during the installation, tensioning, or removal of the chain.

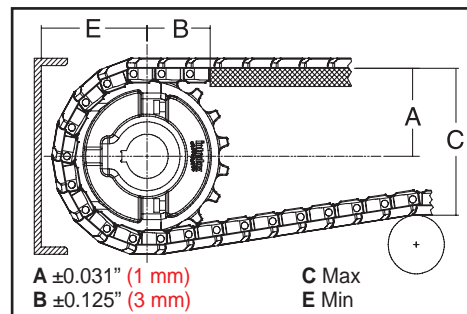

| Sprocket Description |     |           | A                     |       | B    |    | C    |     | E    |    |
|----------------------|-----|-----------|-----------------------|-------|------|----|------|-----|------|----|
| Pitch Diameter       |     | No. Teeth | Range (Bottom to Top) |       | in.  | mm | in.  | mm  | in.  | mm |
| in.                  | mm  |           | in.                   | mm    |      |    |      |     |      |    |
| <b>SERIES 820</b>    |     |           |                       |       |      |    |      |     |      |    |
| 6.0                  | 152 | 25        | 3.02-3.12             | 77-79 | 1.50 | 38 | 6.39 | 162 | 3.34 | 85 |
| <b>SERIES 821</b>    |     |           |                       |       |      |    |      |     |      |    |
| 6.0                  | 152 | 25        | 3.02-3.11             | 77-79 | 1.50 | 38 | 6.42 | 163 | 3.37 | 86 |
| <b>SERIES 831</b>    |     |           |                       |       |      |    |      |     |      |    |
| 6.0                  | 152 | 25        | 2.99-3.08             | 76-78 | 1.50 | 38 | 6.36 | 162 | 3.34 | 85 |
| <b>SERIES 878</b>    |     |           |                       |       |      |    |      |     |      |    |
| 5.8                  | 147 | 12        | 2.94-3.04             | 75-77 | 1.50 | 38 | 6.27 | 159 | 3.29 | 84 |
| <b>SERIES 879</b>    |     |           |                       |       |      |    |      |     |      |    |
| 5.8                  | 147 | 12        | 2.93-3.03             | 74-77 | 1.50 | 38 | 6.24 | 158 | 3.28 | 83 |
| <b>SERIES 880</b>    |     |           |                       |       |      |    |      |     |      |    |
| 5.8                  | 147 | 12        | 2.93-3.03             | 74-77 | 1.50 | 38 | 6.22 | 158 | 3.25 | 83 |
| <b>SERIES 882</b>    |     |           |                       |       |      |    |      |     |      |    |
| 5.8                  | 147 | 12        | 2.96-3.06             | 75-78 | 1.50 | 38 | 6.32 | 161 | 3.32 | 84 |
| <b>SERIES 1060</b>   |     |           |                       |       |      |    |      |     |      |    |
| 5.8                  | 147 | 18        | 2.98-3.03             | 76-77 | 1.00 | 25 | 6.40 | 163 | 3.43 | 87 |

## SPROCKETS AND SHAFTS

- Drive and idler sprockets must be aligned with the centerline of the chain. The sprocket bore is an interference fit; care must be taken to assemble the split sprocket in the correct position. Once tightened, it will be difficult to move along the shaft.
- **FIXED IDLE SHAFTS**—generally, it is preferred to have a rotating idle shaft, so keyed “drive” sprockets would also be used to rotate the shaft in its bearings. If using a fixed idle shaft, use the “idler” sprockets, with a looser bore and no keyway. A fixed idle shaft can be used for chain speeds 100 fpm (30 mpm) and lower.
- If more than one chain is using the same idle shaft, and the shaft is rotating, only the sprocket for one chain should be locked in position (a drive sprocket, with keyway). The other chains should use idler sprockets. They should also be locked using shaft collars to prevent side to side movement.

## CARRYWAY DESIGN

- Care must be taken to ensure that there is adequate clearance for the chain to pass through all guides, tracks, and wearstrip. Transitions between wearstrip sections should be smooth and free of catch points.
- To ensure best results, manually run a short section of chain through the entire conveyor path prior to final installation. Any tight spots or misalignment can then be corrected without having to work around the chain. This will also ensure smooth transition into and out of the sprockets.
- Dimensional information for each chain is in the product line section; below are general clearance numbers.
- For sideflexing chain, additional attention is needed to ensure the proper clearance for the tabs in both the returnway and carryway sections. Minimum turn radius also needs to be factored into the frame design:

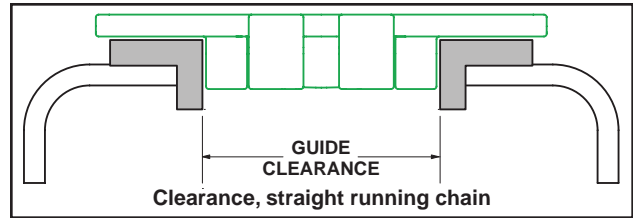

| Straight Running Chains |                 |                 |
|-------------------------|-----------------|-----------------|
| Series                  | Guide Clearance | Guide Clearance |
|                         | in              | mm              |
| 820                     | 1.75            | 44.50           |
| 821                     | 5.50            | 139.70          |
| 831                     | 1.75            | 44.50           |

| Turning Radius |                |                   |     |
|----------------|----------------|-------------------|-----|
| Series         | Width, in (mm) | Centerline Radius |     |
|                |                | in                | mm  |
| 878            | 3.25 (83)      | 7.875             | 200 |
| 879            | 3.25 (83)      | 18                | 457 |
| 879            | 4.50 (114)     | 24                | 610 |
| 880            | 3.25 (83)      | 18                | 457 |
| 880            | 4.50 (114)     | 24                | 610 |
| 882            | 4.50 (114)     | 24                | 610 |
| 882            | 7.50 (191)     | 24                | 610 |
| 882            | 12.00 (305)    | 24                | 610 |
| 1060           | 3.30 (83.8)    | 19.7              | 500 |

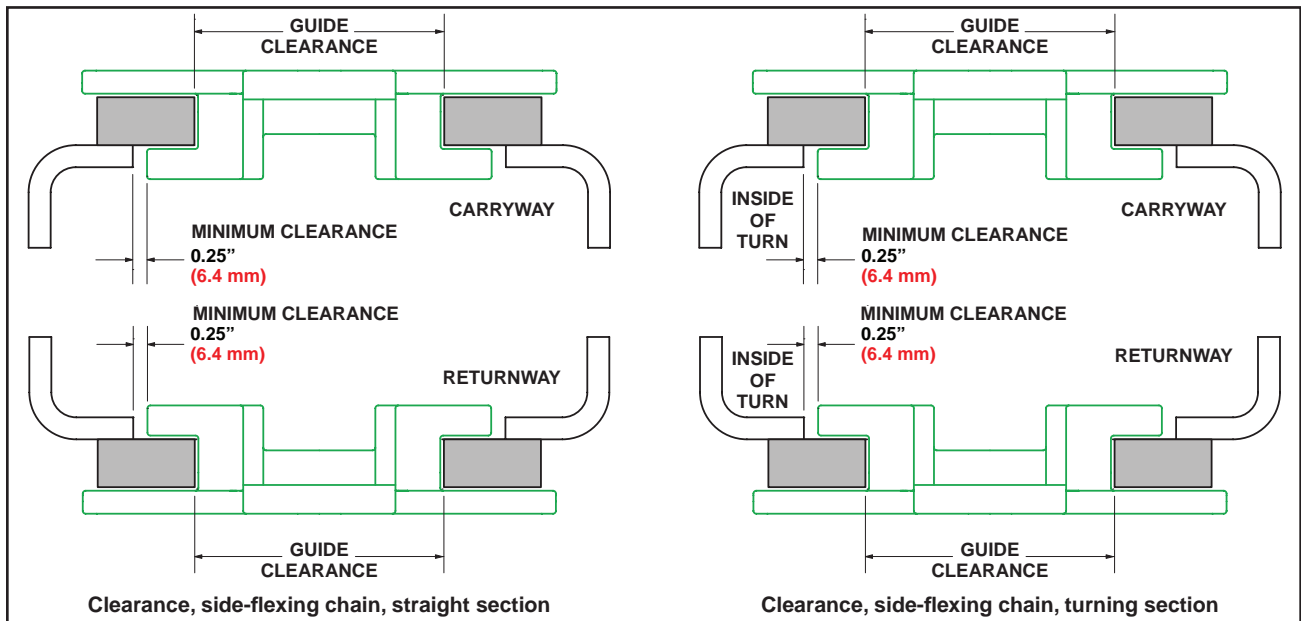

| Side-flexing |                                    |      |                                    |      |                     |      |
|--------------|------------------------------------|------|------------------------------------|------|---------------------|------|
| Series       | Guide Clearance - Straight Section |      | Guide Clearance - Turning Sections |      | Wearstrip Thickness |      |
|              | in                                 | mm   | in                                 | mm   | in                  | mm   |
| 878          | 1.83                               | 46.6 | 1.77                               | 45.1 | 0.38                | 9.7  |
| 879          | 1.81                               | 46.0 | 1.75                               | 44.5 | 0.38                | 9.7  |
| 880          | 1.81                               | 46.0 | 1.75                               | 44.5 | 0.38                | 9.7  |
| 882          | 2.38                               | 60.5 | 2.28                               | 57.9 | 0.63                | 15.9 |
| 1060         | 1.73                               | 44   | 1.73                               | 44   | 0.38                | 9.7  |

## RETURNWAY DESIGN

### Basic Design Elements

- Catenary sag to help accommodate changes in chain length
- Return roller diameter: At least 3 in (76 mm).
- For applications greater than 100 fpm (30 mpm), the use of a snub roller is advised.
- For turning chain, the chain will need to be guided through the curves

### Chain Length

One of the principal functions of the returnway is to properly accommodate the increase (or decrease) in chain length while operating. A chain that increases in length can disengage from its drive sprockets if proper design criteria are not followed. A chain that contracts due to cold temperatures may cause over-tensioning and excessive shaft loads if surplus chain is not provided.

Chains will either elongate or contract during operation because of these factors:

- **Temperature variations:** Assuming chains are installed at average ambient conditions, normally about 70°F (21°C), any significant temperature changes will result in contraction or elongation of the chain.
- **Elongation (strain) under load:** All chains will elongate as tension is applied.
- **Elongation due to break-in and wear:** New chains will usually experience elongation in the first days of operation as the hinge rods and modules “seat” themselves. In severe conditions where heavy loads exist or abrasives are present, older chains may experience elongation due to wear of the hinge rods and enlargement of the modules’ hinge rod holes.

## WEARSTRIP MATERIALS

Material selection is, in most cases, based on the speed of the conveyor. For turning chains, the expected chain pull also affects corner wearstrip guide material.

- **UHMW Polyethylene**
  - General purpose wearstrip material, used on both straight and side-flexing applications
  - Low coefficient of friction against chain materials
  - Not recommended for abrasive applications
  - In side flexing conveyors, not recommended for speeds above 100 fpm (30 mpm)
- **Nylon**
  - Generally recommended for dry applications. In wet applications, the nylon may expand, so additional clearance will need to be accounted for.
  - Lower wear than UHMW PE, similar low friction
  - Can be used above 100 FPM (30 mpm)
- **Stainless Steel**
  - Can be used in very abrasive applications
  - Recommended for dry environments with speeds exceeding 180 fpm/ (60m/min)
  - To minimize wear, the surface should be heat treated to above 25 Rc

### THERMAL EXPANSION AND CONTRACTION

Since plastics expand and contract rather significantly with changes in temperature, chain length changes must be taken into consideration in the conveyor design whenever operating temperatures differ from ambient temperature. An adequate unsupported span in the returnway must be provided to absorb the increase in chain length. In low-temperature applications, the frame must support the chain fully in cold conditions yet not interfere at ambient temperatures.

Changes in the dimensions of a chain are determined in this manner:

$$\Delta = L1 \times (T2 - T1) \times e \text{ where:}$$

$\Delta$  = change in dimension, in. (mm)

L = total chain length at initial temperature, ft. (m)

T2 = operating temperature, °F (°C)

T1 = initial temperature, °F (°C)

e = Coefficient of Thermal Expansion, in/ft/°F (mm/m/°C)

| COEFFICIENTS OF THERMAL EXPANSION  |          |           |
|------------------------------------|----------|-----------|
| MATERIALS                          | in/ft/°F | (mm/m °C) |
| <b>CHAINS</b>                      |          |           |
| LF ACETAL                          | 0.0006   | (0.09)    |
| ULTRA PERFORMANCE                  | 0.0004   | (0.06)    |
| <b>WEARSTRIPS</b>                  |          |           |
| HDPE and UHMW PE                   |          |           |
| -100 °F to 86 °F (-73 °C to 30 °C) | 0.0009   | (0.14)    |
| 86 °F to 210 °F (30 °C to 99 °C)   | 0.0012   | (0.18)    |
| NYLATRON                           | 0.0004   | (0.06)    |
| TEFLON                             | 0.0008   | (0.12)    |
| <b>METALS</b>                      |          |           |
| ALUMINUM                           | 0.00014  | (0.02)    |
| STEEL (Carbon and Stainless)       | 0.00007  | (0.01)    |

### CATENARY SAG

One of the most common methods for controlling chain length is to provide one or more unsupported sections on the return side where the chain may sag. This method of controlling chain length is referred to as the **catenary sag**

**method.** These curves are able to store excess chain by increasing in depth between the top and bottom of the curve. If more than one unsupported returnway section exists, the excess chain length is distributed among all the unsupported sections. Thus, when more of the returnway is equipped with these catenary sections, less vertical space is needed to store the excess chain length.

An adequate amount of returnway tension is needed directly after the drive sprocket for proper chain-to-sprocket engagement. This tension is commonly referred to as **back tension**, which results from the span length and depth of the first catenary sag section directly after the drive sprockets. Back tension is increased as the span is increased or as the depth is decreased. For this reason, the depth of this catenary section should not be allowed to exceed the recommendations in the following illustrations. Care should also be taken to avoid allowing the sagged chain to “bottom out” on the conveyor frame. This will greatly reduce the back tension and may cause sprocket disengagement. In cases when catenary sag is used to accommodate chain length changes, it may be necessary to know the length of the additional or excess chain that is hanging between two adjacent supports and the tension created by that hanging section.

The excess chain, **X**, or the difference between **L** and **D** in the above illustration is found from:

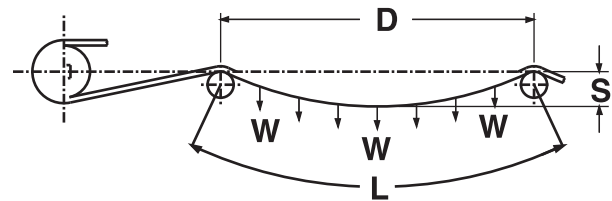

$$X = (2.66 \times S^2)/D \text{ where:}$$

**X** = excess chain, ft (m)

**S** = sag, ft (m)

**D** = distance between supports, ft (m)

All chains have a minimum back bend radius of 1.5 in (38 mm). Therefore, the minimum diameter return rollers will be 3 in (76 mm).

## GENERAL RETURNWAY LAYOUT

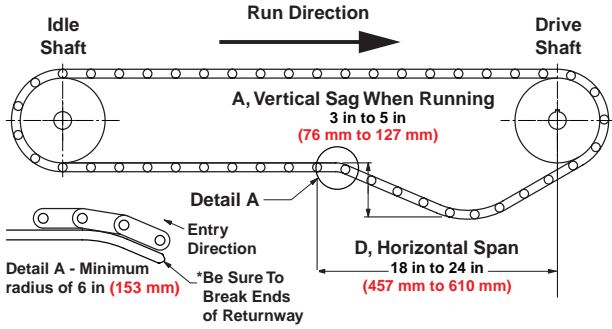

- A** - The amount of catenary sag between each set of return rollers should be between 3 in. (76 mm) and 5 in. (127 mm).
- B** - If a snub roller is used, it should be placed 9 in. (0.23 m) to 18 in. (0.46 m) from the drive and idle shaft. The snub roller should be placed so that the chain has between 150° and 180° of wrap around the sprocket.
- C** - The minimum roller diameter is 3 in. (76 mm)
- D** - Slide beds should begin at least 18 in. (457 mm) from the drive sprockets on conveyors less than 12 ft. (3.6 m) long and 24 in. (610 mm) to 48 in. (914 mm) from the drive sprocket on longer chains. A combination of return rollers and a slide bed can also be used.

Short conveyors [less than 6' (1.8 m)]

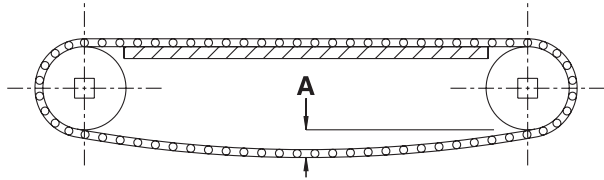

Medium to long conveyors [6' (1.8 m) and longer]

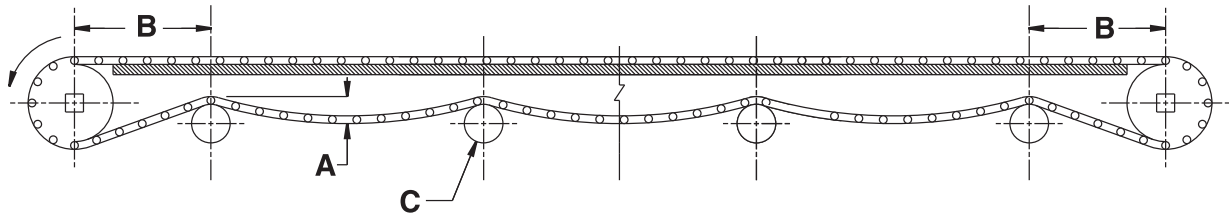

Conveyors with slider beds

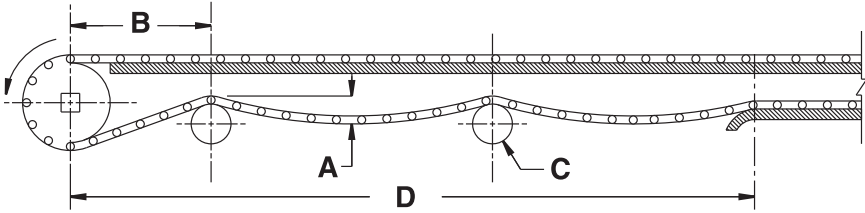

### INSTALLATION/REMOVAL OF PINS ON STRAIGHT RUNNING CHAINS

- Straight chains (820, 821, and 831) have a knurled pin; successful removal depends on removal direction.
- A hammer and punch are the tools needed in most instances.
- The chains are labeled on the bottom of the wing. Drive the knurled pin out using a hammer and punch. The hole on the driving side of the chain is smaller than the diameter of the pin.
- Once the knurl is free, the pin can either be driven all the way out, or pulled from the knurled side.

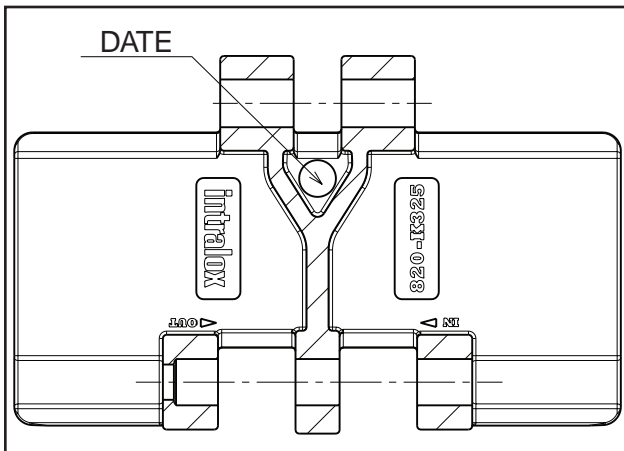

- To reassemble, it is recommended that you start the pin in the “in” hole on the first chain module, then align the chain links. The pin can be pushed or driven in, and is fully set when the head is seated just below the side surface of the chain.

### INSTALLATION/REMOVAL OF PINS ON SIDEFLEXING CHAINS

- To remove, drive the pin through the chain using a hammer and punch.
- To reassemble, start by inserting the “D” pin into the link of the first module. Make sure the pin is oriented correctly. Align the first module to the module it will be assembled to, and drive the pin through both modules using a hammer and punch. The pin is fully set when the head is just below the surface on both sides of the chain.

## MAINTENANCE/ TROUBLESHOOTING

- Check catenary sag
- Check chain, tracks, and sprockets for wear
- If using a fixed idle shaft, check the shaft and sprocket bore for wear
- Ensure rollers on the returnway are still able to turn freely

## REPLACEMENT GUIDE

- When should chains be replaced?
  - When elongation is more than 3%
    - Length of chain over 20 links is greater than 30.9 in (785 mm)
  - When plate thickness has decreased to less than 0.08 in (2.0 mm)
    - Standard & Thick top-plate plastic chains < 2.0 mm
    - Thick top-plate chains exhibit up to 20% more wearlife
  - When damaged links impede chain performance
- Use caution when replacing an older chain, especially if any other components are being reused.
  - When replacing chains due to elongation, replace sprockets as well. It is likely that sprockets will exhibit dramatic wear if the pitch has grown.
  - When replacing chains due to reduction of wing thickness, replace the wearstrips as well. Damage to the wearstrip is common, especially in the turns.
  - When replacing chains due to wear on the top side of the chain, replace rollers/shoes/strips in the return sections as well. Some wear may be the result of damage in the return path.

**Intralox, L.L.C. USA**, New Orleans, LA, +504-733-0463, Toll Free: 1-800-535-8848

**Intralox, L.L.C. Europe**, Amsterdam, The Netherlands, +31-(0)20-540 36 00, Toll Free: +0800-4687-2569

**Intralox Shanghai LTD.**, Shanghai, China, North Toll Free: 10800-711-0100, South Toll Free: 10800-110-0100

**Global Assembly Center Locations: Japan • United Kingdom • Australia • Brazil • India**

Country- and industry-specific toll-free phone numbers, and information on Intralox's global locations, available at [www.intralox.com](http://www.intralox.com).